

3  
4  
5  
6  
7  
8 **Genetic and biogeographic relationships of the racer**  
9 **goby *Neogobius gymnotrachelus* (Gobiidae: Teleostei)**  
10 **from introduced and native Eurasian locations**

11  
12  
13 J. L. OHAYON AND C. A. STEPIEN\*

14 *Great Lakes Genetics Laboratory, Lake Erie Center and Department of Environmental*  
15 *Sciences, the University of Toledo, 6200 Bayshore Road, Toledo, OH, 43618, U.S.A.*

16  
17 (Received 18 January 2007, Accepted 11 July 2007)

18  
19 The racer goby *Neogobius gymnotrachelus*, along with several other neogobiin fishes, has been  
20 spreading north and west from its native Ponto-Caspian range for the past two decades *via*  
21 shipping and canals. It has been predicted as a likely future invader of the North American  
22 Great Lakes, where it would join its neogobiin relatives – the round and freshwater tubenose  
23 gobies. The present study is the first to analyse the population genetic and biogeographic  
24 relationships of the racer goby, establishing a baseline to aid interpretation of its future spread  
25 patterns and likely donor-recipient population relationships. The mitochondrial DNA cyto-  
26 chrome *b* gene was sequenced from representative areas of the racer goby's range, including  
27 rivers of the northern Black Sea and areas of spread upstream in the Danube River and outside  
28 the Ponto-Caspian region to the Vistula River in Poland. Results discerned nine haplotypes,  
29 with few shared among drainages of native rivers and most sites housing unique alleles. Racer  
30 goby populations significantly diverged among watersheds, supporting historic low migration  
31 and little non-anthropogenic gene flow. The Dnieper River was identified as a likely donor  
32 source for the Vistula River colonization, where appreciable variability suggests a relatively  
33 large number of founding genotypes.

© 2007 The Authors

Journal compilation © 2007 The Fisheries Society of the British Isles

34 Key words: Eurasia; exotic species; glacial refugia; Gobiidae; phylogeography; racer goby.

35  
36  
37  
38 **INTRODUCTION**

39  
40 During the past two decades, many native Ponto-Caspian species have anthro-  
41 pogenically expanded their ranges to new habitats in Europe and the North  
42 American Great Lakes through shipping, canals and ballast water exchange  
43 (Ricciardi & MacIsaac, 2000; Kolar & Lodge, 2002; Grigorovich *et al.*,  
44 **I** 2003). These include several species of Ponto-Caspian Neogobiinae Gobiidae  
45 fishes, notably the round goby *Apollonia melanostoma* (Pallas, 1814) and the  
46 freshwater tubenose goby *Proterorhinus semilunaris* (Heckel, 1844) [classification  
47 of the round goby was changed by Stepien & Tumeo (2006) from *Neogobius*  
48  
49

50 \*Author to whom correspondence should be addressed. Tel.: 419 530 8362; fax: 419 530 8399; email:  
51 carol.stepien@utoledo.edu

*melanostomus* due to paraphyly and the freshwater tubenose goby was defined as a separate species from the marine tubenose goby *P. melanostomus*], with the former exerting many ecological changes (Jude *et al.*, 1992; Corkum *et al.*, 2004; Stepien & Tumeo, 2006). Other neogobiins, including the racer goby *Neogobius gymnotrachelus* (Kessler, 1857) examined in the present study, are also predicted to enter and become established in the Great Lakes (Kolar & Lodge, 2002), rendering baseline population genetic data critically important for correct taxonomic identification as well as to diagnose likely donor population pathways.

The historic range of the racer goby *N. gymnotrachelus* (Fig. 1) comprises fresh and slightly brackish waters of the northern rivers and estuaries leading to the Black, Azov and Caspian Seas; including the Danube, Dniester, southern Bug, Dnieper and Don Rivers (Miller, 2003; Grabowska, 2005; Jurajda *et al.*, 2005). During the past decade, the racer goby spread through many Eurasian waterways, with its first recording in the mid-1990s from the middle section of the Western Bug River (the Vistula River basin) (Grabowska, 2005). The racer goby then spread quickly throughout the Vistula River, to the middle and lower regions down to Toruń, Poland (site 1; Fig. 1) (Grabowska & Grabowski, 2005; Kakareko *et al.*, 2005). Upstream expansion of the racer goby occurred throughout the Danube River basin, with establishment in Serbia, Bratislava, Slovakia (site 2; Fig. 1) (Kautman, 2001) and Vienna, Austria by the late 1990s (Wiesner, 2005).

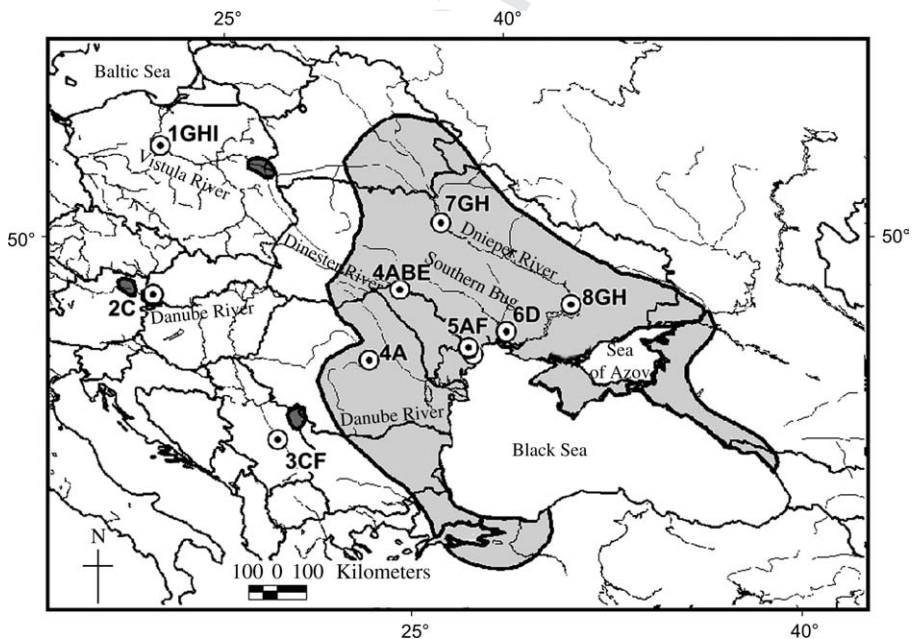

FIG. 1. Map indicating locations of sampling sites (numbered 1–8; Table II) surrounding the Black and Azov Seas in Europe. Solid shading indicates original range of the racer goby *Neogobius gymnotrachelus* and hatching denotes regions of range expansion, following Miller (2003). Letters designate haplotypes (A–I) found at each location (some of the collections are located outside the published range expansion areas, attributed to more recent spread).

1  
2  
3 Various factors have been proposed as potentially contributing to recent  
4 neogobiin spread throughout Eurasia, including ballast water transport, dam  
5 and reservoir construction, climate change, pollution and natural migration  
6 patterns (Miller, 2003; Vasil'eva, 2003; Grabowska, 2005). Neogobiins lack  
7 a larval stage, and the adults have no swimbladder (Pinchuk, 1991), which  
8 [4] may help to reduce their natural dispersal. Anthropogenic transport of the  
9 round goby *Apollonia melanostomus* to the Great Lakes has been attributed  
10 to ballast water uptake of juveniles that rise to feed in the water column at  
11 night and are benthic during the day (Hensler & Jude, 2007). Like other neo-  
12 gobiins, the racer goby's plasticity in foraging behaviour and prey utilization  
13 may aid adaptedness in new habitats (Kostrzewa & Grabowski, 2003; Grabowska  
14 & Grabowski, 2005; Kakareko *et al.*, 2005). Also, characteristic of most neo-  
15 gobiins, the racer goby's long spring reproductive period and parental care may  
16 augment establishment (Grabowska, 2005), with the males guarding nests under  
17 shells, stones or vegetation for *c.* 2 weeks until the eggs hatch (Georghiev, 1966;  
18 [5] Grabowska, 2005). However, the racer goby is rarer in new habitats in compar-  
19 ison to the round goby or the bighead goby *Neogobius kessleri* (Jurajda *et al.*,  
20 2005), meriting further studies to evaluate their spread and establishment  
21 patterns.

22 Understanding the role of population genetics during a non-indigenous spec-  
23 ies introduction is critical for making correct ecological comparisons between  
24 donor-recipient populations, undertaking a comprehensive risk analysis  
25 (Stepien *et al.*, 2005) and for acting preemptively to prevent further spread.  
26 The current study aimed to provide a genetic baseline for understanding the  
27 racer goby's historic, present and future population patterns. Mitochondrial  
28 cytochrome *b* gene sequences were analysed from exotic and native populations  
29 of the racer goby across Eurasia. Although several studies previously examined  
30 the racer goby's ecology (Kostrzewa & Grabowski, 2003; Grabowska, 2005;  
31 Kakareko *et al.*, 2005), this was the first investigation of its population genetics,  
32 thus providing an important comparison to other neogobiins (Dillon & Stepien,  
33 2001; Stepien *et al.*, 2005; Stepien & Tumeo, 2006), Ponto-Caspian taxa and to  
34 exotic species overall. These baseline population genetic data will facilitate cor-  
35 rect ecological comparisons among donor-recipient areas in the future.

## 36 37 38 METHODS

39 Racer goby samples were collected by hook-and-line or seining and then stored in  
40 95% ethanol at room temperature. A total of 80 specimens were analysed from native  
41 and range expansion locations in Eurasia (Fig. 1). Although the present sampling  
42 efforts aimed to be comprehensive, sample sizes varied due to the rarity of the racer  
43 goby in some regions. Thus, a conservative approach was taken in this study in inter-  
44 preting the results.

45 Genomic DNA was extracted from fin or muscle tissue and purified using the  
46 DNeasy tissue kit and protocol (Qiagen, Inc., Valencia, CA, U.S.A.). The mitochon-  
47 drial cytochrome *b* gene was amplified using the polymerase chain reaction (PCR) in  
48 25 µl reactions containing 2 µl (*c.* 100 ng) of template DNA, 10 mM Tris-HCl pH  
49 8.3, 50 mM KCl, 1.5 mM MgCl<sub>2</sub>, 1 µM of each primer, 200 µM of each dNTP and  
50 1.5 units of *Taq* polymerase. Primers were AJG15 (Akihito *et al.*, 2000) and H15343g  
(5'-GGGTTATTAGATCCTGTTTCGTGTAGG-3'; designed by graduate student M.  
51 Neilson). A negative control containing no template DNA was used in each run.

PCR reactions comprised 35 cycles of 45 s at 94° C (denaturation), 30 s at 52° C (annealing) and 60 s at 72° C (extension), followed by a final extension step for 3 min. The double-stranded PCR products were visualized on an agarose gel stained with ethidium bromide and then purified using a QIAquick kit (Qiagen, Inc.). Sequencing was performed separately in both directions for verification at the Cornell University Life Sciences Core Laboratories Center (<http://cores.lifesciences.cornell.edu/brcinfo>) using an automated Applied Biosystems 3730 sequencer and the primer sets Song F (Song *et al.*, 1998) and HI5149 (Kocher *et al.*, 1989).

Sequences were aligned and haplotypes identified using Bioedit, version 7.0 (Hall, 1999; <http://www.mbio.ncsu.edu/BioEdit/bioedit.html>) with ClustalW alignment. Genetic analysis was performed on the consensus sequence of 445 bp of the left domain of the cytochrome *b* gene using the Arlequin software package, version 3.0 (Excoffier *et al.*, 2005). Comparative measures of genetic variability included the frequency and distribution of haplotypes and haplotype diversity (*i.e.* the probability that two individuals chosen at random will have different haplotypes). The probability that samples from different river drainages significantly differed was measured using pair-wise  $F_{ST}$  analog ( $\theta_{ST}$ ; Weir & Cockerham, 1984) and genetic differentiation contingency tests (Raymond & Rousset, 1995), with sequential Bonferroni correction (Rice, 1989).

A tree of haplotype relationships was constructed using the neighbour-joining algorithm (Saitou & Nei, 1987) in MEGA version 3.1 (Molecular Evolutionary Genetics Analysis; Kumar *et al.*, 2004) and 1000 bootstrap pseudo-replications were used to evaluate relative support (Felsenstein, 1985). Neogobiin species believed to be most closely related to the racer goby, *e.g.* *Neogobius syrman* (Nordmann, 1840), *Neogobius platyrostris* (Pallas, 1814) and *Mesogobius batrachocephalus* (Pallas, 1814) per Stepien & Tumeo (2006) were used as outgroups. A haplotype network was constructed (modelled after Avise, 2000) to further assist in elucidating their relationships.

## RESULTS

Nine mtDNA cytochrome *b* gene haplotypes of the racer goby *N. gymnotrachelus* were discerned that differed at 12 nucleotide positions and were deposited as accession numbers AY884589 [reference haplotype G, from earlier work of Stepien *et al.* (2005) and Stepien & Tumeo (2006)] and EF584743-50 (haplotypes A–F, and H and I) in the NIH GenBank database (<http://www.ncbi.nlm.nih.gov>) (Table I). All substitutions were transitions and all but one occurred at the third codon position. Haplotypes clustered in three groups (A–E, F–G, and H and I), shown in the neighbour-joining tree (Fig. 2) and haplotype network (Fig. 3). Haplotypes A–E differed by single substitutions (Table I and Figs 2 and 3), whereas haplotype F diverged from that group by three substitutions, equivalent to 0.67% pair-wise divergence. Haplotypes G and F differed by a single nucleotide. A greater difference distinguished the clade comprising haplotypes H and I (found in the Dnieper and Vistula Rivers), which diverged from F by five nucleotides, and a pair-wise distance of 1.12% (Table I and Figs 2 and 3).

Few haplotypes were shared among native river systems, with most characterized by unique haplotype assemblages (Tables I–III). Racer goby populations across their native range showed significant genetic divergences among river systems, using both  $F_{ST}$  analogs (Weir & Cockerham, 1984) and  $\chi^2$  contingency test comparisons (Raymond & Rousset, 1995) (Table III).

In the Dniester River, haplotype A was predominant, representing 78% of the north-west sample and 86% in the south-east (Table II). In the north-west Dniester River, haplotypes B and E also occurred, each constituting 11% of

TABLE I. Haplotypes and their distinguishing single nucleotide polymorphism characters identified in the mtDNA cytochrome *b* gene of the racer goby. Nucleotide positions are numbered according to the GenBank submissions, which are AY884589 for haplotype G (Stepien *et al.*, 2005, Stepien & Tumeo, 2006) and EF584743-50 for haplotypes A–F, and H and I. The sequence for haplotype A is shown at all variable sites, and the bases for other haplotypes are shown only in nucleotide positions that differ from A

Haplotype letter	GenBank numbers	68	84	141	156	204	219	228	303	342	354	381	396
A	EF584746	t	g	t	t	a	a	t	c	c	c	t	g
B	EF584748	c											
C	EF584744				c								
D	EF584750										t		
E	EF584747							c					
F	EF584743							c	t				a
G	AY884589							c	t			c	a
H	EF584745		a	c		g	g	c	t	t			a
I	EF584749		a	c		g	g	c	t	t			a

the sample. Along with haplotype A, F was found in the south-east Dniester River and made up 14% of the individuals. Haplotype F was also found in the Danube River at Tekija, Serbia, where it was common. Three of four haplotypes (A, B and E) found in the Dniester River were unique (Table II) and closely related (Fig. 2). The north-west Dniester River samples were more diverse ( $h = 0.417$ ) than the south-east ( $h = 0.240$ ; Table II).

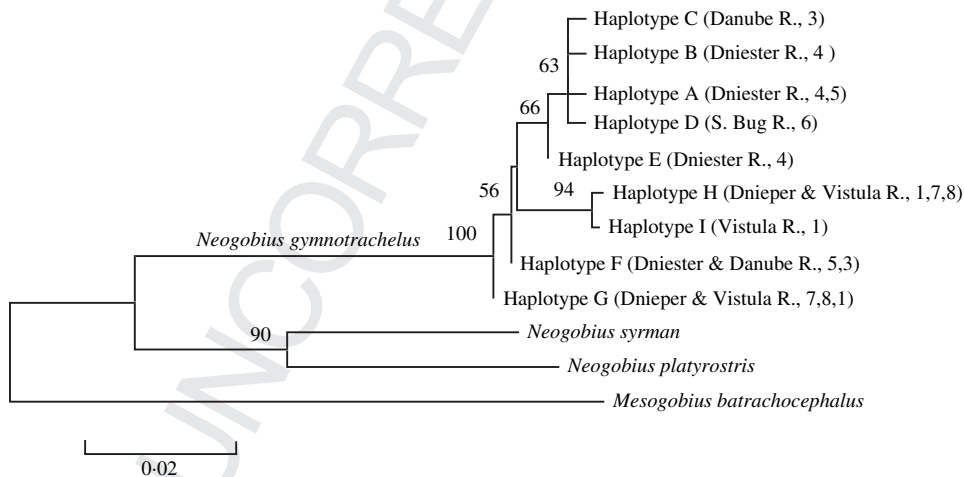

FIG. 2. Neighbour-joining tree of relationships among racer goby cytochrome *b* sequence haplotypes (lettered A–I according to Table I), constructed with MEGA version 3.1 (Nei *et al.*, 2004). Numbers at nodes denote bootstrap per cent support values, determined using 1000 pseudo-replications. Parentheses denote river sites and sampling locations (1–8) in which each haplotype was found, corresponding to Table II and Fig. 1. Closely related species to the racer goby (Stepien & Tumeo, 2006) were used as outgroups.

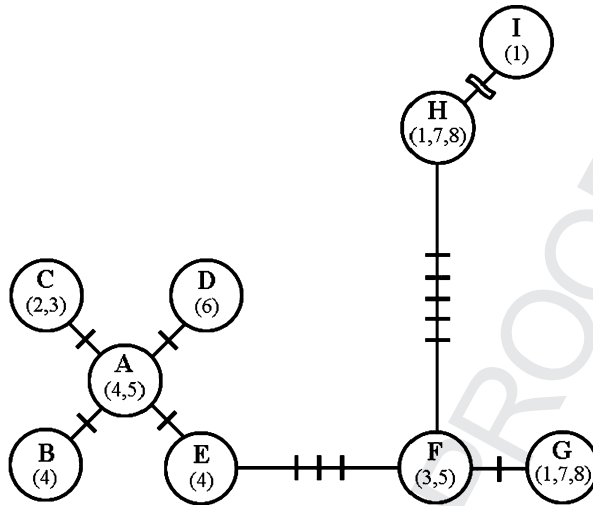

FIG. 3. Haplotype network (modelled after Avise, 2000) for mitochondrial cytochrome *b* DNA sequences of the racer goby *Neogobius gymnotrachelus*. Each circle represents a unique haplotype denoted by A–G (Table I). Solid dashes on lines connecting the haplotypes represent the number of nucleotide substitutions that differentiate them. Unfilled curved dashes indicate a reversal (homoplasy) to a previous base.

Haplotype C was present in the Danube River at Bratislava, Slovakia, constituting 100% of the sample as well as in Serbia (Table II). Haplotype C is closely related to A–E (found in the Dniester and southern Bug Rivers; Fig. 2). Two haplotypes were identified from the Danube River invasive location at Tekija, Serbia, comprising 75% F and 25% C. Haplotype F was rare elsewhere, occurring only in the south-east Dniester River sample at 14% frequency (Table II). Haplotype F is closely related to haplotype G and somewhat more distantly to A–E (see haplotype network of Fig. 2) and was present in the Dniester, Danube and southern Bug Rivers.

In the southern Bug River at Mykolaiv, Ukraine, only a single individual was sampled, whose haplotype (D) appeared unique to that site (Table II). Haplotype D was closely related to types A–E from the Dniester and Danube Rivers (Figs 2 and 3). In the Dnieper River, two haplotypes were detected (G and H), which were shared between the northern and southern sites (Table II). Haplotype G made up 80% of the northern and 50% of the southern Dnieper River sample, whereas H totalled 20% in the north and 50% in the south (Table II). The Dnieper River samples shared haplotypes G and H with the invasive Vistula River site, which were exclusively found in these locations. The Vistula River sample comprised 83% H and 0.08% G, although the latter appeared more common in the northern Dnieper River. The Vistula River sample appeared genetically closest to the Dnieper River samples.

## DISCUSSION

MtDNA cytochrome *b* haplotypes of the racer goby *N. gymnotrachelus* are partitioned among different river systems across their native range, revealing

TABLE II. Sampling locations (with numbers corresponding to the map of Fig. 1) and their mtDNA cytochrome *b* gene haplotype frequencies and diversities for populations of the racer goby *Neogobius gymnotrachelus* (population location 4 includes sampling sites at Makarovka and Yampil in Ukraine representing the north-west Dniester River, and location 5 includes Belgorod-Dnestrovsky and Bilyayivka in Ukraine as the south-east Dniester River; grouped according to their geographic proximity and similar haplotype distribution)

Sampling location	Body of water	Site	Sample size	Number of haplotypes	Haplotype distribution	Haplotype diversity
1 (introduced)	Vistula River	Toruń, Poland	12	3	0-08G 0-83H 0-08I	0-319
2 (introduced)	Danube River	Bratislava, Slovakia	5	1	1-00C	0-000
3 (introduced)	Danube River	Tekija, Serbia	4	2	0-25C 0-75F	0-500
4 (native)	North-west Dniester River	Makarovka & Yampil, Ukraine	9	3	0-78A 0-11B 0-11E	0-417
5 (native)	South-east Dniester River	Belgorod-Dnestrovsky and Bilyayivka, Ukraine	37	2	0-86A 0-14F	0-240
6 (native)	Southern Bug River	Mykolaiv, Ukraine	1	1	1-00D	N/A
7 (native)	Northern Dnieper River	Kiev, Ukraine	10	2	0-80G 0-20H	0-356
8 (native)	Southern Dnieper River	Zaporizhzhya Reservoir, Ukraine	2	2	0-50G 0-50H	1-000

TABLE III. Pair-wise population  $F_{ST}$  analog (Weir & Cockerham, 1984) (below the diagonal) and  $\chi^2$  contingency test comparisons (Raymond & Rousset, 1995) (above the diagonal) among river system population samples of the racer goby *Neogobius gymnotrachelus*, using Arlequin, version 3.0 (Excoffier *et al.*, 2005). Numbers under locations correspond to sampling sites of Table II. \*Significantly different following sequential Bonferroni correction (Rice, 1989)

	Vistula River 1	Danube River 2, 3	Dniester River 4, 5	Dnieper River 7, 8
Vistula River 1	—	*	*	*
Danube River 2, 3	0.791*	—	*	*
Dniester River 4, 5	0.892*	0.378*	—	*
Dnieper River 7, 8	0.582*	0.518*	0.756*	—

significant population structure and little historic gene flow among indigenous sites in different watersheds. The neighbour-joining tree and phylogeographic network of haplotype relationships elucidated three groups of haplotypes, whose divergences likely stemmed from their glacial refugium histories and merit further sampling and investigation. The present study provides the first genetic evidence that the Dnieper River in Ukraine (part of the native range of the species) is the likely source population for the racer goby's invasion of the Vistula River, Poland. The Pripyat-Bug Canal system (termed an 'invasion corridor'; Bij de Vaate, 2002) connects the Dnieper, Pripyat, western Bug and Vistula Rivers (Grabowska, 2005) and is the most probable route for the racer goby's expansion.

Conventional population genetic theory states that non-indigenous populations are likely to be subject to a 'founder effect', originating from a few individuals that carry only a small proportion of the source population's genetic diversity (Mayr, 1963; Williamson, 1996). However, racer goby haplotype diversity appears appreciable in expansion sites in the Danube River at Tekija, Serbia and the Vistula River at Toruń, Poland, which may be a product or combination of the following: (1) the colonization sources in turn having considerable haplotype diversity (*e.g.* the Dnieper River in the case of the Vistula River), (2) several independent introductions into the expansion areas, and/or (3) a high propagule number and rate of spread into new areas. Exotic populations of round and tubenose gobies in the North American Great Lakes likewise have high genetic diversities, similar to those of native Ponto-Caspian populations (Dillon & Stepien, 2001; Stepien *et al.*, 2005; Stepien & Tumeo, 2006). In addition, non-indigenous populations of the round goby genetically diverge among the Great Lakes (as well as across Eurasia), supporting all three of the above-listed factors (Dillon & Stepien, 2001; Stepien *et al.*, 2005; Stepien & Tumeo, 2006). Further sampling and analysis of racer goby populations across their native and introduced ranges, as well as additional comparisons with other neogobiins and other Ponto-Caspian taxa, will provide important information for interpreting the role of genetic diversity in their spread.

In contrast, no haplotype diversity was discerned in a region of the Danube River located further upstream at Bratislava, Slovakia, where the racer goby was first recorded in 1999 (Kautman, 2001). This upstream site may have lower

genetic diversity than downstream locations due to its recency or as an artefact of the small sample size, which should be further tested.

Interconnection of European river basins through canal construction dates to the 17th century (Bij de Vaate *et al.*, 2002) and thus cannot account entirely for the sharp and sudden peak in range expansion of the racer goby (and other neogobiins) since the 1990s, following their historic confinement to the Ponto-Caspian region. Moreover, lack of detailed historical and modern collection data complicate attempts at reconstructing their spread patterns. As sampling is often concentrated around urban centres, it is difficult to discern whether new colonizations result from 'sudden' transport *via* ballast water or gradual expansion through canals and waterways. Genetic analysis of additional samples along waterways would aid in interpreting these patterns and the mechanism for population spread.

In summary, this study comprises a baseline for elucidating the invasion population genetics and phylogeographic history of the racer goby, providing important comparative data for interpreting its future range expansion and those of other taxa. These mitochondrial cytochrome *b* sequence data revealed marked divergence among native populations of the racer goby in different river systems, which is useful for tracing their historic and contemporary relationships.

This is publication number 2007-XX from the Lake Erie Research Center. This research was supported by National Science Foundation grant DEB-0456972 to C.A.S. J.L.O. was supported by the University of Toledo's Lake Erie Center's NSF Research Experiences for Undergraduates programme grant EAR-9552552, led by Alison Sponberg and Christine Mayer. Great Lakes Genetics Laboratory (GLGL) PhD students Joshua E. Brown and Matthew E. Neilson generously gave laboratory help and training for J.L.O. Other valuable laboratory help was provided by GLGL members Douglas Murphy, Amanda Haponski, Osvaldo Jhonatan Sepulveda Villet, Rachel Lohner and Ian Hoffman. Collections were aided by Yuriy Kvach, Igor Grigorovich, Mykola Checheniuk, Tomasz Kakareko, Vladimir Kovac, Predrag Simonovic, Vasily Boldyrev and Matthew Neilson. Lake Erie Center personnel James Coss designed the map, Patricia Uzmans provided logistic support, and Rachel Lohner helped with proof-reading and formatting.

## References

- Akihito, I. A., Kobayashi, T., Ikee, K., Imanishi, T., Ono, H., Umehara, Y., Hamamatsu, C., Sugiyama, K., Ikeda, Y., Sakamoto, K., Fumihito, A., Ohno, S. & Gojobori, T. (2000). Evolutionary aspects of gobioid fishes based upon a phylogenetic analysis of mitochondrial cytochrome *b* genes. *Gene* **259**, 5–15.
- Avice, J. C. (2000). *Phylogeography: The History and Formation of Species*. Cambridge, MA: Harvard University Press.
- Bij de Vaate, A., Jazdzewski, K., Ketelaars, H. A. M., Gollasch, S. & Van der Velde, G. (2002). Geographical patterns in range extension of Ponto-Caspian macroinvertebrate species in Europe. *Canadian Journal of Fisheries and Aquatic Sciences* **59**, 1159–1174.
- Corkum, L. D., Sapota, M. R. & Skora, K. E. (2004). The round goby, *Neogobius melanostomus*, a fish invader on both sides of the Atlantic Ocean. *Biological Invasions* **6**, 173–181.
- Dillon, A. K. & Stepien, C. A. (2001). Genetic and biogeographic relationships of the invasive round (*Neogobius melanostomus*) and tubenose (*Proterorhinus marmoratus*)

- gobies in the Great Lakes versus Eurasian populations. *Journal of Great Lakes Research* **27**, 267–280.
- Felsenstein, J. (1985). Confidence limits on phylogenies: an approach using the bootstrap. *Evolution* **39**, 783–791. doi: 10.1111/j.1558-5646.2007.00073.x
- Georghiev, J. M. (1966). Composition d'espece et caracteristique des Gobiides (Pisces) en Bulgaria. *Izv. Nauch. Issled. Inst. Rib. Stop. Okeanogr Varna*, **7**, 159–288.
- Grabowska, J. (2005). Reproductive biology of racer goby *Neogobius gymnotrachelus* in the Wloclawski Reservoir (Vistula River, Poland). *Journal of Applied Ichthyology* **21**, 296–299. doi: 10.1111/j.1439-0426.2005.00675.x
- Grabowska, J. & Grabowski, M. (2005). Diel-feeding activity in early summer of racer goby *Neogobius gymnotrachelus* (Gobiidae): a new invader in the Baltic basin. *Journal of Applied Ichthyology* **21**, 282–286. doi: 10.1111/j.1439-0426.2005.00676.x
- Grigorovich, I. A., Colautti, R. I., Mills, E. L., Holeck, K., Ballert, A. G. & MacIsaac, H. J. (2003). Ballast-mediated animal introductions in the Laurentian Great Lakes: retrospective and prospective analyses. *Canadian Journal of Fisheries and Aquatic Sciences* **60**, 740–756.
- Hensler, S. & Jude, D. (2007). Diel vertical migration of round goby larvae as a potential mechanism for advective dispersal and ballast water transport. *Journal of Great Lakes Research* **33** (in press).
- Jude, D. J., Reider, R. H. & Smith, G. R. (1992). Establishment of Gobiidae in the Great Lakes basin. *Canadian Journal of Fisheries and Aquatic Sciences* **49**, 416–421.
- Jurajda, P., Cerny, J., Polacik, M., Valova, Z., Janac, M., Blazek, R. & Ondrackova, M. (2005). The recent distribution and abundance of non-native *Neogobius* fishes in the Slovak section of the River Danube. *Journal of Applied Ichthyology* **21**, 319–323. doi: 10.1111/j.1439-0426.2005.00688.x
- Kakareko, T., Zbikowski, J. & Zytkowicz, J. (2005). Diet partitioning in summer of two syntopic neogobiids from two different habitats of the lower Vistula River, Poland. *Journal of Applied Ichthyology* **21**, 292–295. doi: 10.1111/j.1439-0426.2005.00683.x
- Kautman, J. (2001). The first occurrence of *Neogobius gymnotrachelus* in the Slovak Danube. *Folia Zoologica* **50**, 79–80.
- Kocher, T. D., Thomas, W. K., Meyer, A., Edwards, S. B., Paabo, S., Villablanca, F. X. & Wilson, C. (1989). Dynamics of mitochondrial DNA evolution in animals: amplification and sequencing with conserved primers. *Proceedings of the National Academy of Sciences of the United States of America* **86**, 6196–6200.
- Kolar, C. S. & Lodge, D. M. (2002). Ecological predictions and risk assessment for alien fishes in North America. *Science* **298**, 1233–1236.
- Kostrzewa, J. & Grabowski, M. (2003). Opportunistic feeding strategy as a factor promoting racer goby (*Neogobius gymnotrachelus* Pallas, 1811) expansion in the Vistula basin. *Lauterbornia* **48**, 91–100.
- Mayr, E. (1963). *Animal Species and Evolution*. Cambridge, MA: Harvard University Press.
- Miller, P. J. (ed.). (2003). *The Freshwater Fishes of Europe. Mugilidae, Atherinidae, Atherinopsidae, Blenniidae, Odontobutidae, Gobiidae I*, Vol. 8/I. Wiebelsheim: AULA-Verlag.
- Pinchuk, V. I. (1991). [About speciation within the genus *Neogobius* (Perciformes)]. *Voprosy Ikhtiologii* **31**, 180–393 [in Russian].
- Raymond, M. & Rousset, F. (1995). An exact test for population differentiation. *Evolution* **49**, 1280–1283.
- Ricciardi, A. & MacIsaac, H. J. (2000). Recent mass invasion of the North American Great Lakes by Ponto-Caspian species. *Trends in Ecology and Evolution* **15**, 62–65.
- Rice, W. R. (1989). Analyzing tables of statistical tests. *Evolution* **43**, 223–225.
- Saitou, N. & Nei, M. (1987). The neighbor joining method: a new method for reconstructing phylogenetic trees. *Molecular Biology and Evolution* **4**, 406–425.
- Song, C. B., Near, T. J. & Page, L. M. (1998). Phylogenetic relations among percid fishes as inferred from mitochondrial cytochrome *b* DNA sequence data. *Molecular Phylogenetics and Evolution* **10**, 343–353.

- 1  
2  
3 Stepien, C. A. & Tumeo, M. A. (2006). Invasion genetics of Ponto-Caspian gobies in the  
4 Great Lakes: a 'cryptic' species, absence of founder effects, and comparative risk  
5 analysis. *Biological Invasions* **8**, 61–78.
- 6 Stepien, C. A., Brown, J. E., Neilson, M. E. & Tumeo, M. A. (2005). Genetic diversity of  
7 invasive species in the Great Lakes versus their Eurasian source populations:  
8 insights for risk analysis. *Risk Analysis* **25**, 1043–1060. doi: 10.1111/j.1539-  
9 6924.2005.00655.x
- 10 Vasil'eva, E. D. (2003). Main alterations in ichthyofauna of the largest rivers of the  
11 northern coast of the Black Sea in the last 50 years: a review. *Folia Zoologica* **52**,  
12 337–358.
- 13 Weir, B. S. & Cockerham, C. C. (1984). Estimating F-statistics for the analysis of  
14 population structure. *Evolution* **38**, 1358–1370.
- 15 Wiesner, C. (2005). New records of non-indigenous gobies (*Neogobius* spp.) in The  
16 Austrian Danube. *Journal of Applied Ichthyology* **21**, 324–327. doi: 10.1111/j.1439-  
17 0426.2005.00681.x
- 18 [9] Williamson, M. (1996). *Biological invasions*. London: Chapman & Hall, Inc.

### 19 [10] Electronic References

- 20 Excoffier, L., Laval, G. & Schneider, S. (2005). Arlequin version 3.0: an integrated  
21 software package for population genetics data analysis. *Evolutionary Bioinformatics*  
22 *Online* **1**, 47–50. Available at: <http://cmpg.unibe.ch/software/arlequin3/>
- 23 Kumar, S., Tamura, K. & Nei, M. (2004). MEGA 3.0: integrated software for molecular  
24 evolutionary genetics analysis and sequence alignment. *Briefings in Bioinformatics*  
25 **5**, 150–163. Available at: <http://www.megasoftware.net/>
- 26  
27  
28  
29  
30  
31  
32  
33  
34  
35  
36  
37  
38  
39  
40  
41  
42  
43  
44  
45  
46  
47  
48  
49  
50  
51  
52

# Author Query Form

---

**Journal: Journal of Fish Biology**

**Article : jfb\_1659**

Dear Author,

During the copy-editing of your paper, the following queries arose. Please respond to these by marking up your proofs with the necessary changes/additions. Please write your answers on the query sheet if there is insufficient space on the page proofs. Please write clearly and follow the conventions shown on the attached corrections sheet. If returning the proof by fax do not write too close to the paper's edge. Please remember that illegible mark-ups may delay publication. Many thanks for your assistance.

---

Query No.	Query	Remark
1	Please provide the genus name for ' <i>P. melanostomus</i> ' and also provide the authority names for ' <i>P. melanostomus</i> ' and ' <i>Neogobius melanostomus</i> ' in the sentence 'These include...'. <hr/>	
2	Please note the footnote '1' has been moved to the text in the sentence 'These include...'. <hr/>	
3	Please note that the name of the author 'Grabowskia' in 'Grabowska & Grabowska, 2005' has been changed to 'Grabowski' as per the list. Please check. <hr/>	
4	Please provide the authority name for ' <i>Apollonia melanostomus</i> ' in the sentence 'Anthropogenic transport...'. <hr/>	
5	Please provide the authority name for ' <i>Neogobius kessleri</i> ' in the sentence 'However, the racer...'. <hr/>	
6	Please note that the reference 'Hall (1999)' is not listed. Please add it to the list or delete the citation. <hr/>	
7	Please provide expansion of the journal name ' <i>Izv. Nauch. Issled. Inst. Rib. Stop. Okeanogr. Varna</i> ' in the reference 'Georghieve (1996)'. <hr/>	
8	Please update the reference 'Hensler & Jude (2007)'. <hr/>	
9	Please provide the city name for the publisher 'Chapman & Hall, Inc.' in the reference 'Williamson (1996)'. <hr/>	
10	Please note that the references 'Excoffier et al. (2005)' and 'Kumar et al. (2004)' have been moved to Electronic References section. Please check.	

---

11 The supplied figures 1 & 3 are in low resolution with poor quality. Could you provide us a better higher resolution figures.

---

UNCORRECTED PROOF

# MARKED PROOF

## Please correct and return this set

Please use the proof correction marks shown below for all alterations and corrections. If you wish to return your proof by fax you should ensure that all amendments are written clearly in dark ink and are made well within the page margins.

<i>Instruction to printer</i>	<i>Textual mark</i>	<i>Marginal mark</i>
Leave unchanged	... under matter to remain	Ⓟ
Insert in text the matter indicated in the margin	∧	New matter followed by ∧ or ∧ <sup>Ⓢ</sup>
Delete	/ through single character, rule or underline or ┌───┐ through all characters to be deleted	Ⓞ or Ⓞ <sup>Ⓢ</sup>
Substitute character or substitute part of one or more word(s)	/ through letter or ┌───┐ through characters	new character / or new characters /
Change to italics	— under matter to be changed	↵
Change to capitals	≡ under matter to be changed	≡
Change to small capitals	≡ under matter to be changed	≡
Change to bold type	~ under matter to be changed	~
Change to bold italic	≈ under matter to be changed	≈
Change to lower case	Encircle matter to be changed	≡
Change italic to upright type	(As above)	⊕
Change bold to non-bold type	(As above)	⊖
Insert 'superior' character	/ through character or ∧ where required	Υ or Υ under character e.g. Υ or Υ
Insert 'inferior' character	(As above)	∧ over character e.g. ∧
Insert full stop	(As above)	⊙
Insert comma	(As above)	,
Insert single quotation marks	(As above)	ʹ or ʸ and/or ʹ or ʸ
Insert double quotation marks	(As above)	“ or ” and/or ” or ”
Insert hyphen	(As above)	⊥
Start new paragraph	┌	┌
No new paragraph	┐	┐
Transpose	┌┐	┌┐
Close up	linking ○ characters	○
Insert or substitute space between characters or words	/ through character or ∧ where required	Υ
Reduce space between characters or words		↑