

# Computer Science & Engineering Technology Curriculum – Full Time

(Effective Fall 2005)

## FRESHMAN

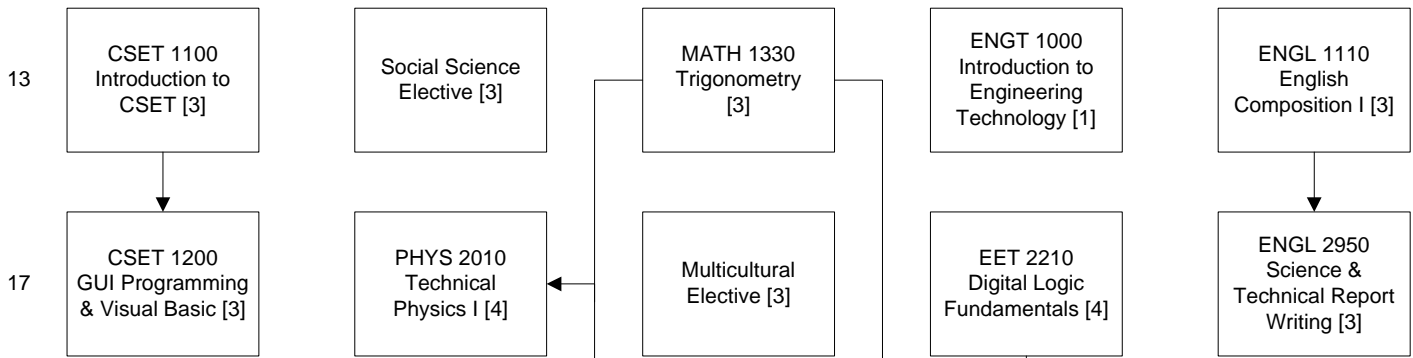

## SOPHMORE

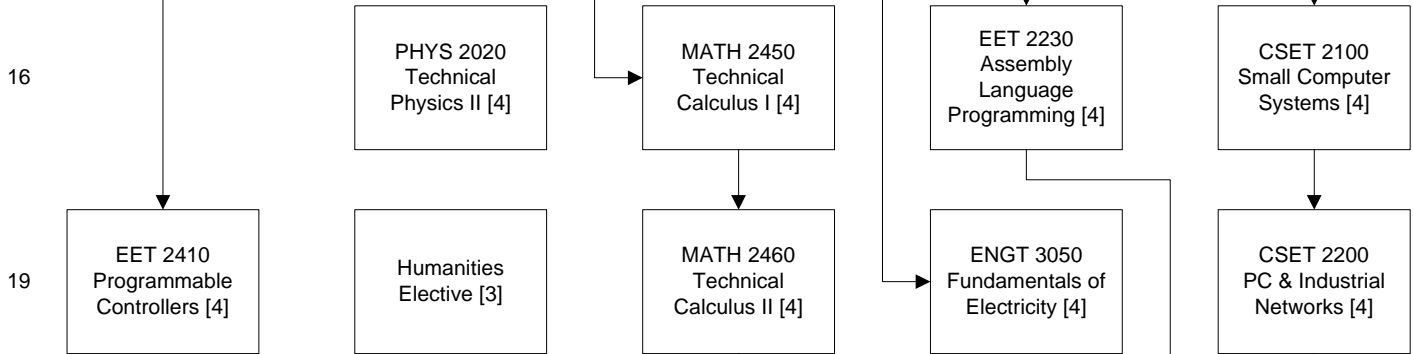

## JUNIOR

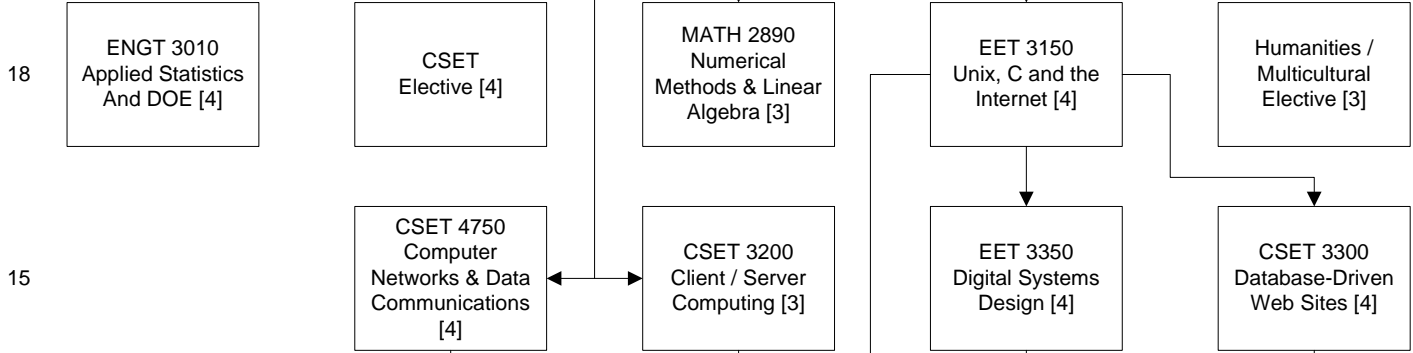

## SENIOR

