

Handout 1: Introduction to Crystals & Crystallography

Chem 4850/6850/8850

X-ray Crystallography

Department of Chemistry & Biochemistry

cora.lind@utoledo.edu



THE UNIVERSITY OF
TOLEDO

Crystallography - what and why?

- **What?**

- Determination of the atomic structure of crystalline solids
- Location and type of atoms, bond distances/local environment
- Absolute structure

- **Why?**

- Materials' properties are intimately related to their structures
 - Understanding certain properties requires knowledge of atomic arrangement, e.g., piezoelectrics
- Structural studies of enzyme active sites can allow the rational selection of inhibitors
- Impact of crystallography can be seen in the large number of Nobel Prizes for work related to crystallography or diffraction

Historical development

- **X-rays were discovered by Wilhelm Conrad Röntgen in 1895**
 - “Interested in the effects of ultra-violet radiation, he covered a cathode-ray discharge tube with black paper and darkened the room. With the glow from the tube hidden, Röntgen was surprised to see a fluorescent screen two metres away light up. For several weeks, Röntgen hid in his laboratory, finding out more about the mysterious penetrating 'X' rays, produced when the cathode rays hit the end of the discharge tube.” (IUCr history page)
- **In 1912, Max von Laue discovered that X-rays are diffracted by crystals**
 - Copper sulfate, recorded on film
- **In 1913, Sir William Henry and William Lawrence Bragg formulated their famous Bragg law**
 - Birth of “crystallography”



Early Crystallography and Materials

- The first crystal structure ever solved was NaCl
- Clearly showed equally spaced sodium and chlorine atoms and thus proved the concept of ions and ionic bonding!
 - First proof that not all materials are made up of molecules!
 - Admittedly, not everybody was happy to accept this...
 - Armstrong, H. Nature, 1927, 120, 478-478

Prof. W. L. Bragg asserts that, "In sodium chloride there appear to be no molecules represented by NaCl. The equality in number of sodium and chlorine atoms is arrived at by a chess-board pattern of these atoms; it is a result of geometry and not of a pairing-off of the atoms". This statement is more than repugnant to common sense it is absurd to the n^{th} degree; not chemical cricket. Chemistry is neither chess nor geometry, whatever X-ray physics may be... It were time chemists took charge of chemistry once more and protected neophytes against the worship of false gods; at least taught them to ask for something more than chess-board evidence."



Nobel Prizes Related to Crystallography

- This presentation used to have a slide that listed many Nobel Prizes – but even with a very small font size, there was not enough space!
- Check out <https://www.iucr.org/people/nobel-prize> for a comprehensive list of Nobel prizes in this field!
- Over 30 Nobel prizes – 9 of them were awarded since I started teaching at UToledo!

What is possible today?

- Determination of small molecule structures is routine nowadays
 - This was not true 50 years ago!
 - Takes 6-12 h of data collection in most cases
- Crystal structures of macromolecules can be solved from single crystal data
- Synchrotron radiation can in some cases yield single crystal structures from crystals that are smaller than 10 μm
- Powder methods are becoming more advanced and can in some cases enable full structure determinations, too

What is a crystal?

- **Historic definition before the advent of crystallography**
 - A solid with well-defined faces
- **Crystallographic definition**
 - A material with a regularly repeating structural motif
- **The strict definition is more vague**
 - Any material that gives a diffraction pattern with sharp peaks

Repeating motif: The unit cell

- The repeating structural motif in a crystal is referred to as a unit cell
 - Only the size and contents of one unit cell are necessary to describe the entire crystal
- Remember to use a right-handed axis system!

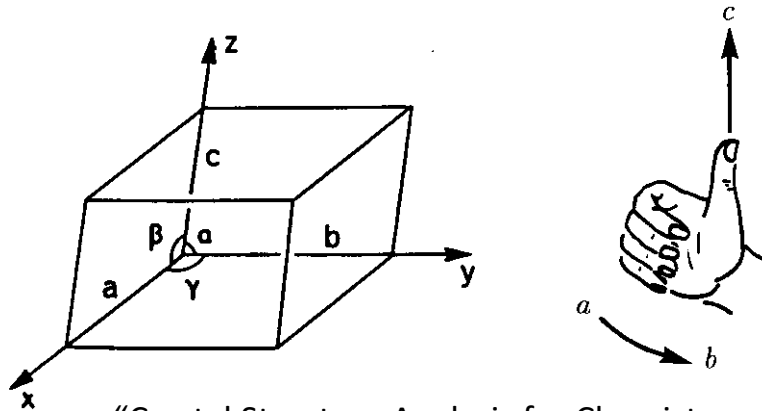

“Crystal Structure Analysis for Chemists and Biologists”, Glusker, Lewis and Rossi, VCH, 1994.

The seven crystal systems

Crystal system	Unit cell edges	Unit cell angles
Cubic	$a = b = c$	$\alpha = \beta = \gamma = 90^\circ$
Hexagonal	$a = b \neq c$	$\alpha = \beta = 90^\circ, \gamma = 120^\circ$
Rhombohedral	$a = b = c$	$\alpha = \beta = \gamma \neq 90 \text{ or } 120^\circ$
Tetragonal	$a = b \neq c$	$\alpha = \beta = \gamma = 90^\circ$
Orthorhombic	$a \neq b \neq c$	$\alpha = \beta = \gamma = 90^\circ$
Monoclinic	$a \neq b \neq c$	$\alpha = \gamma = 90^\circ, \beta \neq 90 \text{ or } 120^\circ$
Triclinic	$a \neq b \neq c$	$\alpha \neq \beta \neq \gamma \neq 90 \text{ or } 120^\circ$



Crystal growth

- **First event: Nucleation**

- Depends strongly on availability of nucleation sites (container surfaces, impurities etc.)

- **Growth of the nuclei**

- Usually not isotropic, high-energy faces grow fastest
- Relative growth rates of faces can be influenced by additives to the solution

- **Size distribution of crystals depends on relative nucleation and growth rates**

- High nucleation rates and low growth rates result in many small crystals

Methods of crystal growth

- **Choice of method depends on material**
 - Optimization for each problem
- **Growth from solution**
 - “Normal” solvents like water, organic solvents
 - Molten solids (NaCl, PbO, metals...)
 - Ideally, the solvent should dissolve the reactants and product(s)
 - Recent development esp. for proteins: Growth in zero gravity
- **Growth from the vapor phase**
 - Not very common

Crystal growth from the vapor phase

- Can be used for some sublimable materials
 - Menthol
- Can also be used for materials that can be transported by the addition of a transporting agent
 - $\text{ZnS}_{(\text{solid})} + \text{I}_{2(\text{gas})} \rightarrow \text{ZnI}_{2(\text{gas})} + 1/8 \text{S}_{8(\text{gas})}$
 - T-dependent equilibrium
 - Also used in “halogen lamps”: WX_6 will transport tungsten back to the filament!

Crystal growth from a melt

- Special case of “growth from solution”
- Not possible for all materials
 - Material must be stable above the melting point
 - Phase diagram must allow direct crystallization

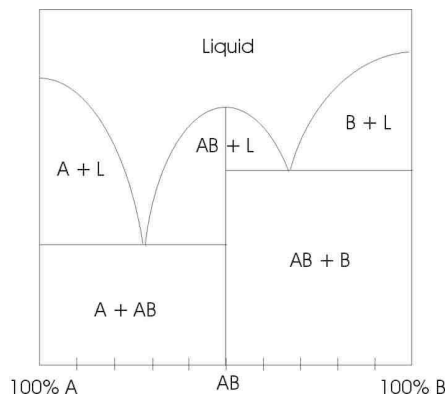

Congruently melting

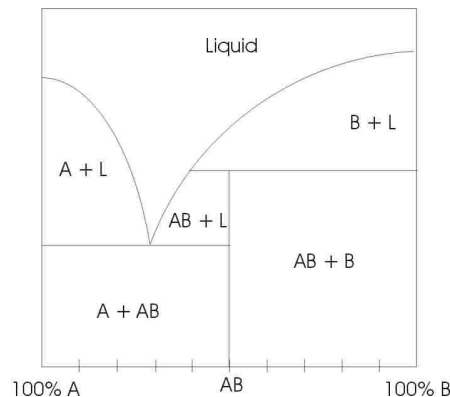

Incongruently melting

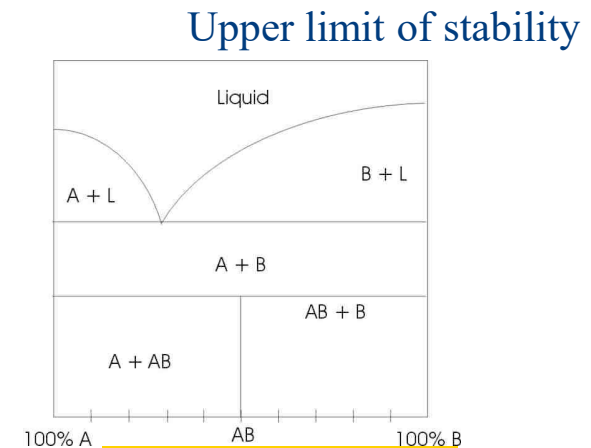

Crystal growth from a flux

- **Strict definition of a flux: A liquid reaction medium that dissolves the reactants and products, but does not participate in the reaction**
- **Often used for growth from a molten “solvent” that dissolves the reactants**
 - Reactants should be soluble to at least a few weight %
 - Product solubility improves chances of growing big crystals
- **Use of a “solvent” for the reactants improves kinetics of product formation**
 - Possibility to grow materials that are not stable at high temperatures or in the molten state

Crystal growth from solution

- Most commonly used method (esp. in organic and biochemistry)
- Crystals form from a saturated solution
- Manipulating the saturation limit allows control of precipitation rate
 - Slow cooling of the liquid
 - Slow evaporation of the solvent
 - Addition of other components that change the solubility of the desired product (e.g., varying the polarity of an organic solvent)



<http://chemconnections.org/crystals/new/intro.htm>



Specialized methods: Czochralski growth

- First developed for the growth of metal single crystals
- Most commonly used commercial single crystal growth method
 - Well suited for semiconductors like Si, GaAs
 - Can also be applied to oxides, e.g., Nd:YAG, Ti:sapphire
- Growth is accomplished from a seed crystal that is slowly pulled out of the melt
 - Commonly produces crystals with 10 inches in diameter and several feet long



Laif Alden with a Si single crystal grown by the Czochralski method



Vapor and solute diffusion

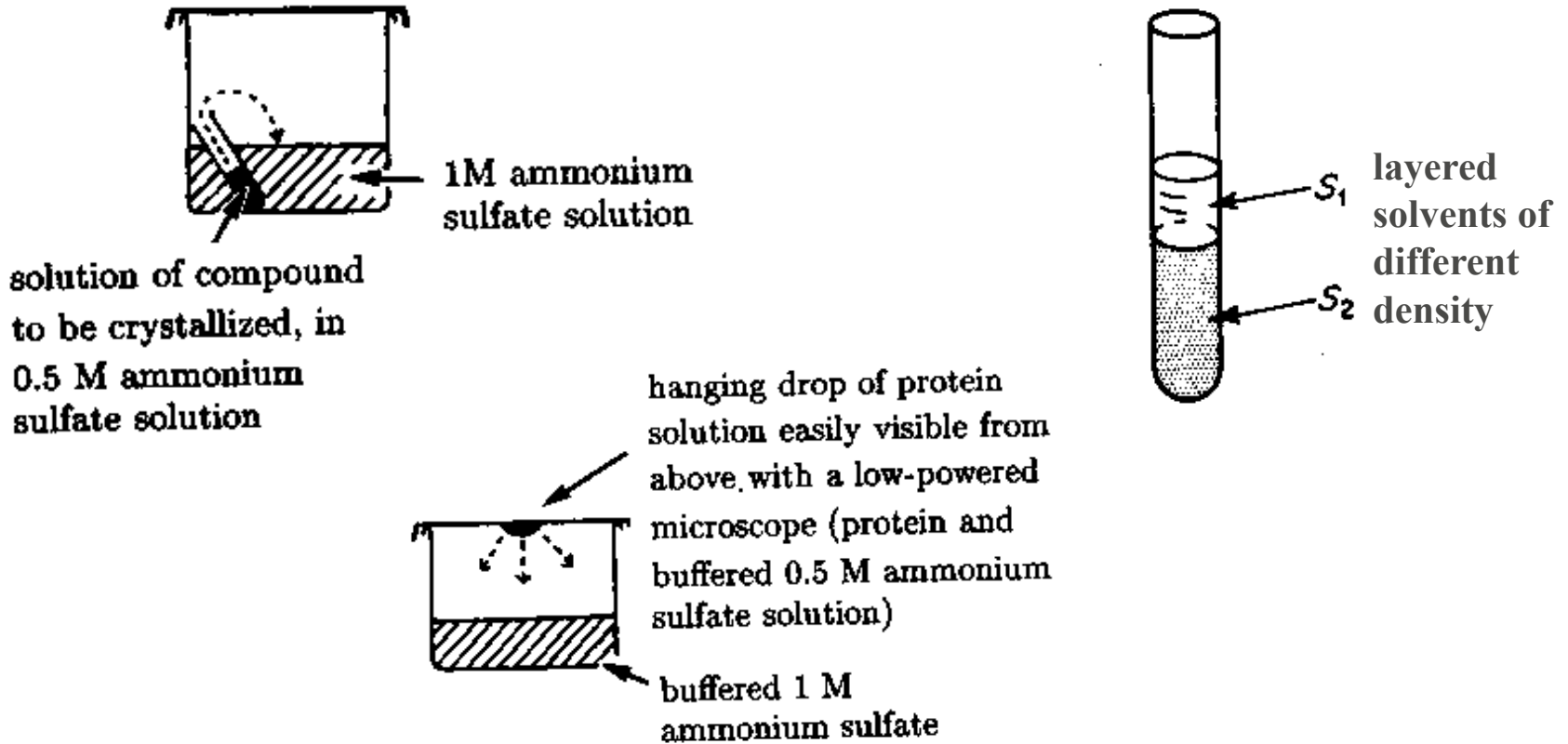

“Crystal Structure Analysis for Chemists and Biologists”,
Glusker, Lewis and Rossi, VCH, 1994.



Crystal habit

- The external shape of a crystal is referred to as crystal habit
- Visible faces correspond to slow growing faces, fast growing faces result in corners
- The crystal habit can be affected by the growth conditions (e.g., additives to the growth solution may change the habit)
 - high energy faces will grow fastest
- Crystal habit can often be correlated to crystal symmetry
 - e.g., a cubic crystal should grow isotropically
 - interfacial angles can allow determination of crystal system



Interfacial angles

- The angles between external faces of crystals are not arbitrary, but characteristic of a material
 - can be measured with a goniometer

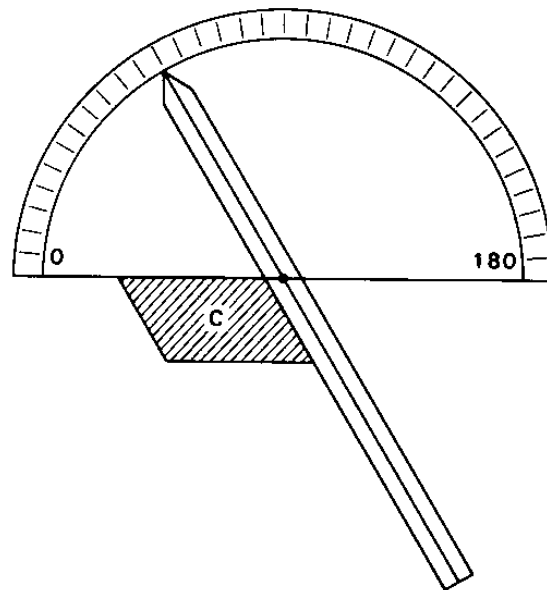

Examples of crystal habits

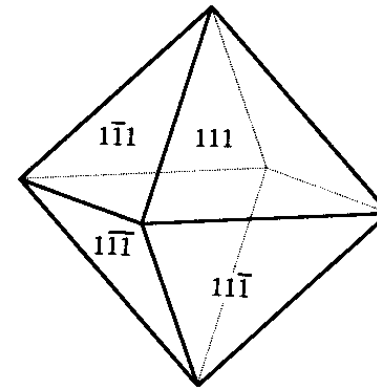
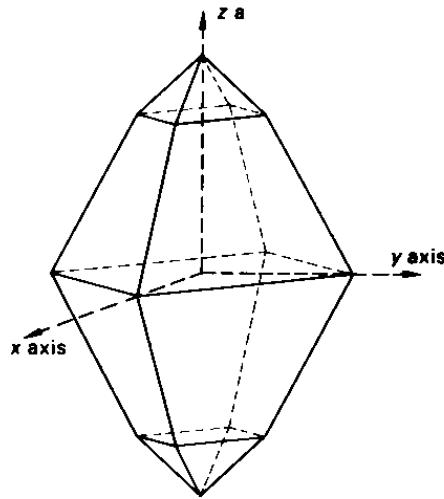
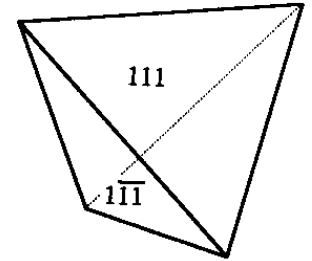
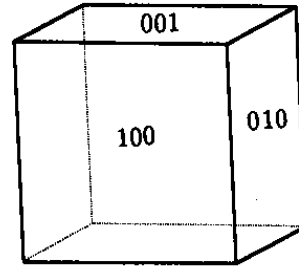
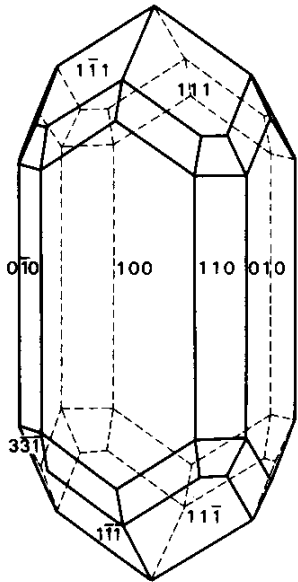

“Crystal Structure Analysis for Chemists and Biologists”, Glusker, Lewis and Rossi, VCH, 1994.

“Structure Determination by X-ray Crystallography”, Ladd and Palmer, Plenum, 1994.



Miller indices

- The external crystal faces can be described by Miller indices h, k, l
 - correlated to unit cell symmetry
 - reciprocal of intersection of plane (face) with unit cell axes
 - all parallel planes can be described with the same indices (use lowest numbers)

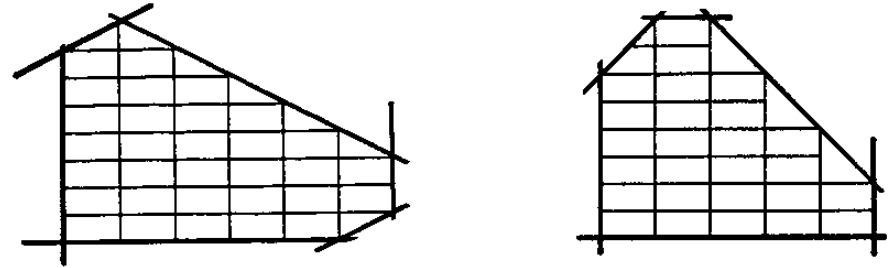

Faces cutting unit cell axes in two dimensions

“Crystal Structure Analysis for Chemists and Biologists”,
Glusker, Lewis and Rossi, VCH, 1994.



Miller indices in 3D

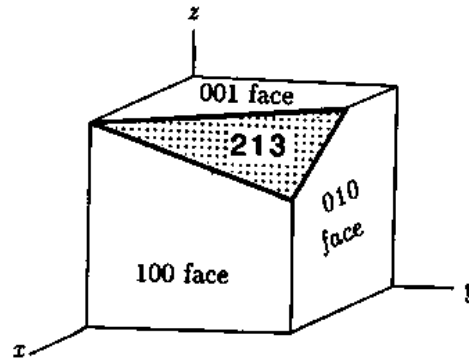
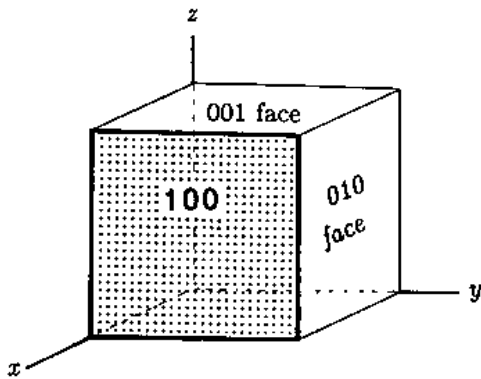
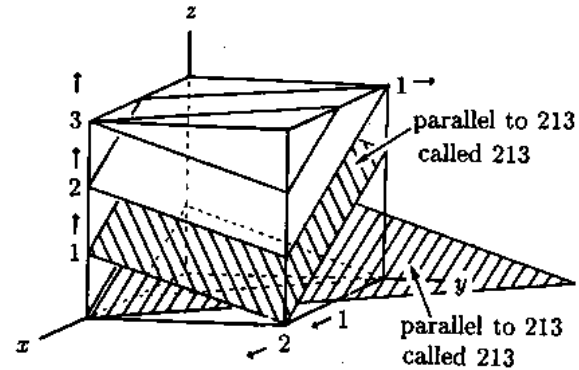
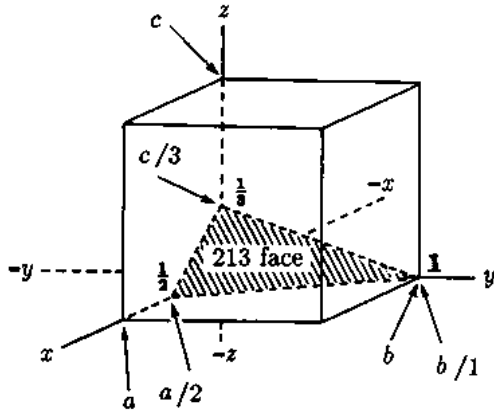

"Crystal Structure Analysis for Chemists and Biologists", Glusker, Lewis and Rossi, VCH, 1994.



How do we determine a structure?

- **Oldest methods relied on simple physical observations only**
 - Example: Crystal habit
 - Could determine symmetry of crystal, but usually not atomic scale structure
- **NMR has become one of the most powerful structural tools for organic molecules**
 - Can also be used for amorphous materials
 - Often less straightforward for solids and/or non-standard nuclei
- **Crystallographic methods**
 - Gives detailed time-averaged picture in 3D
 - Works only for crystalline materials



Electron microscopy

- **Electron microscopy is a powerful tool for the visualization of particles and/or lattices (high resolution)**
- **Electrons can be focused using magnetic lenses**
- **Gives structural information on a short length scale**
 - Provides a 2D image
 - Samples are often damaged by the intense electron beams
 - Only very thin samples can be measured
- **Atomic resolution imaging is now possible**
 - Images can be difficult to interpret



Picking the appropriate probe

- Light scattering can give “structural” information on the length scale of light waves
 - Light microscopy
 - Measurement of particle size distributions by light scattering

- Analysis of atomic length scale ordering requires a probe with the appropriate wavelength
 - Typical bond distances are 1-3 Å
 - X-rays have Angstrom wavelengths

- How do we focus X-rays without appropriate lenses?

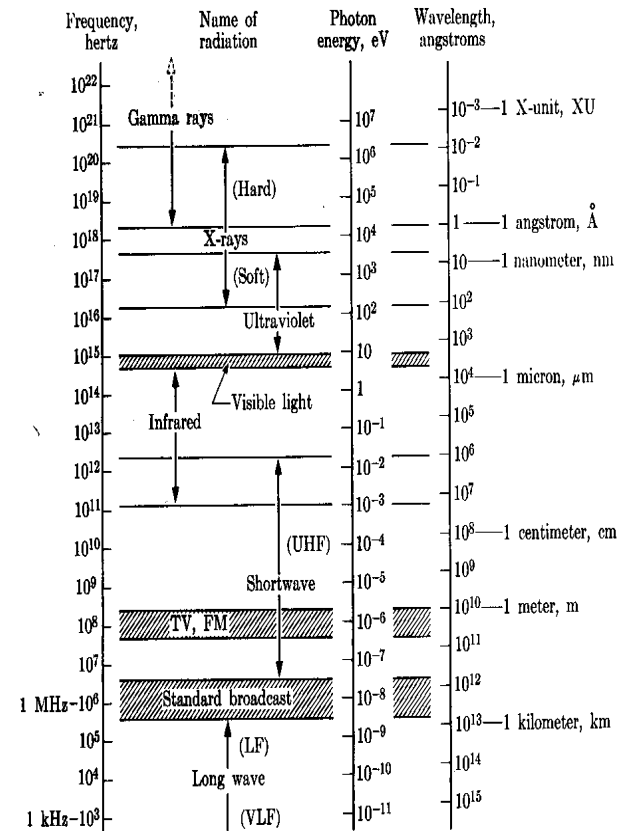

Cullity, “Elements of X-ray Diffraction”



How a microscope works

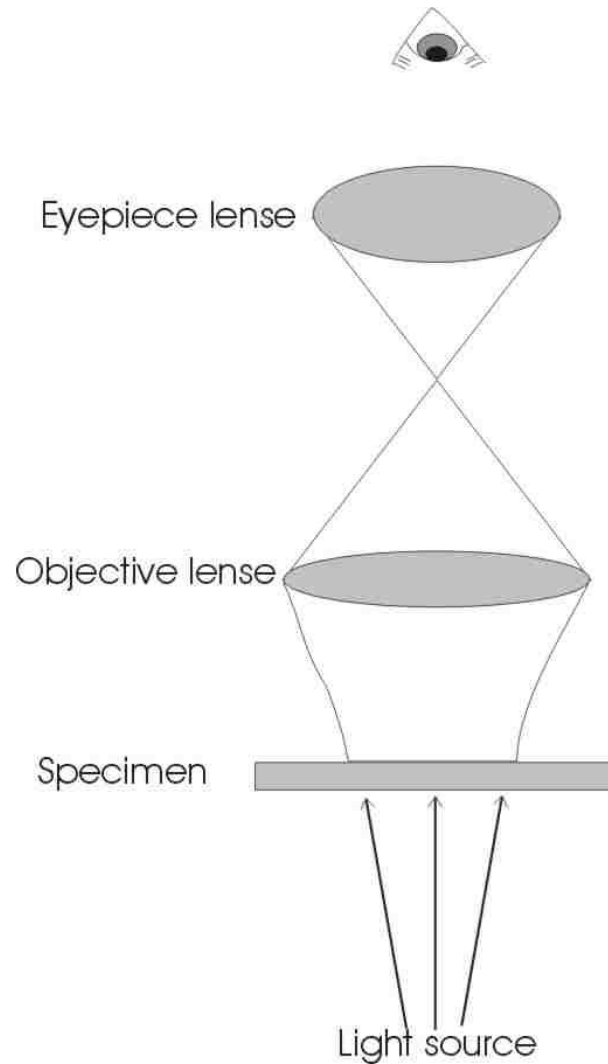

- Light is focused using lenses



Ways of focusing X-rays

- **There are no refractive lenses for X-rays, as the refractive index in all materials is close to 1**
 - Between 0.99 and 0.999
- **X-rays can be focused using diffraction-based optics**
 - e.g., a “peak” of X-rays is used as the source
- **At small incident angles, X-rays can be focused by using X-ray mirrors**
 - grazing incidence
 - usually, $<0.5^\circ$ for Pt at 10 keV

X-ray cathodes

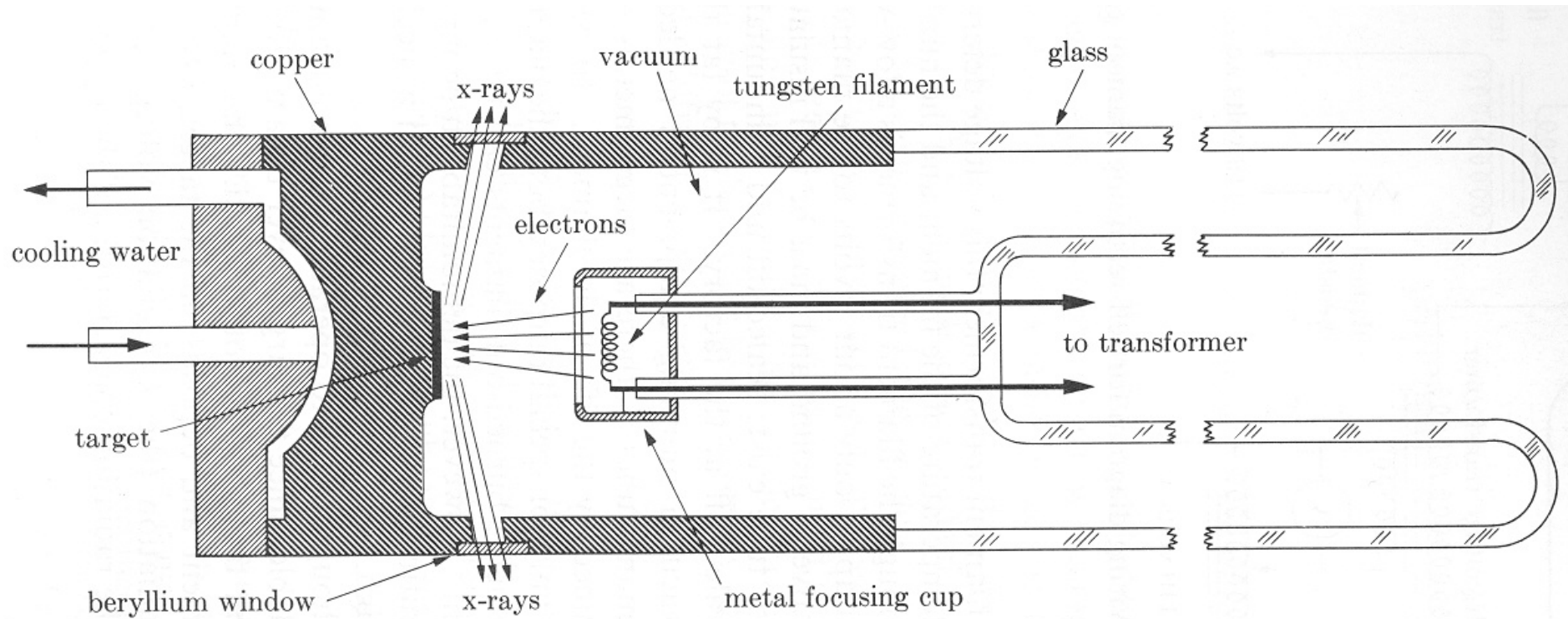

Cullity, "Elements of X-ray Diffraction"



Typical setup for a diffraction experiment

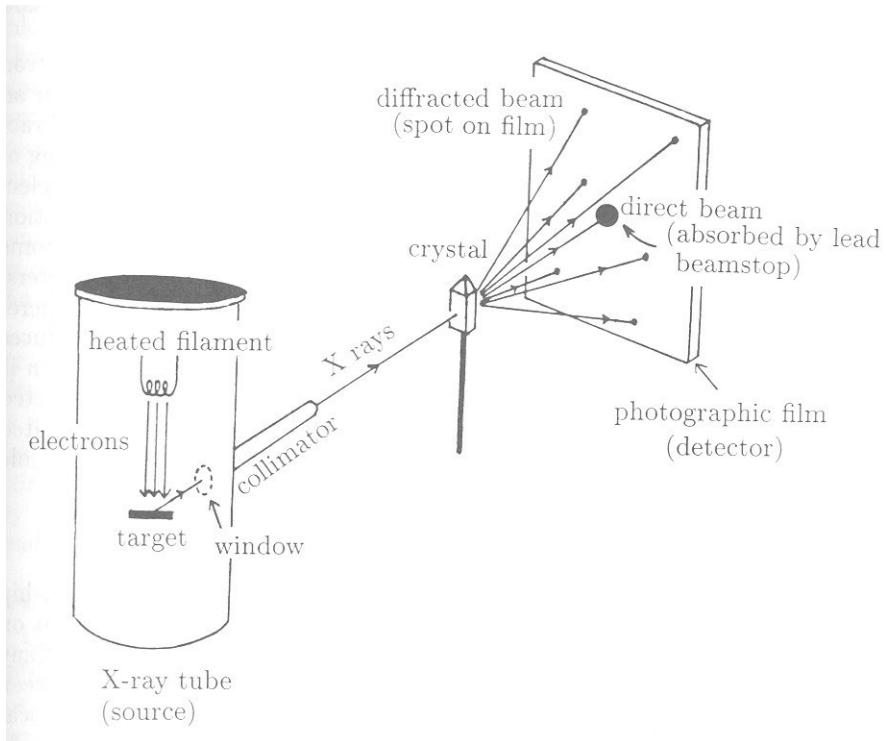

“Crystal Structure Analysis for Chemists and Biologists”,
Glusker, Lewis and Rossi, VCH, 1994.

Specimen C on support table H, can be rotated around axis O; X-ray source S with line focal spot on the target T; A, B and F are defining/focusing slit systems; counter G supported by carriage E, which can also be rotated around O, angular position can be read on scale K. E and H are mechanically coupled so that E rotates twice as far.

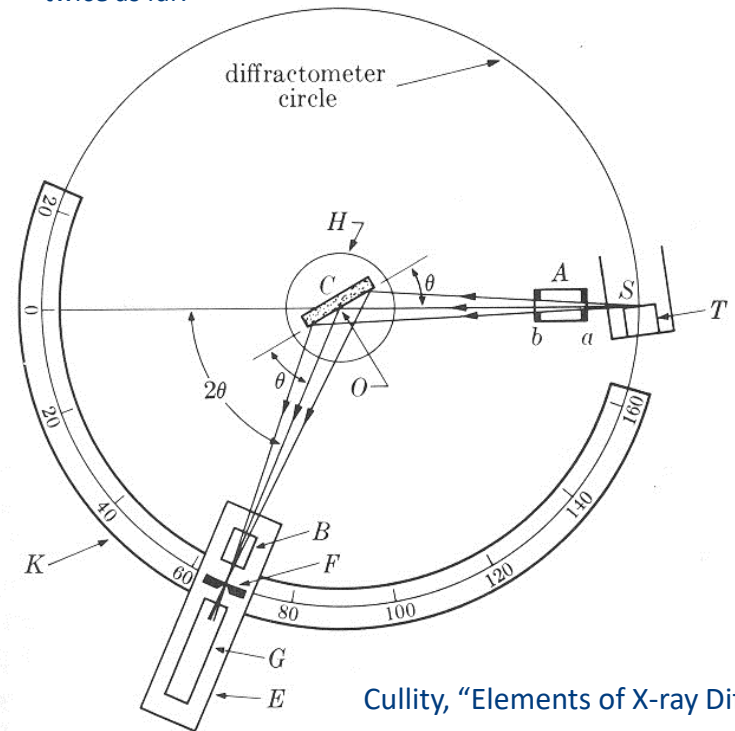

Cullity, “Elements of X-ray Diffraction”

